

# SN54LVT244A, SN74LVT244A 3.3-V ABT OCTAL BUFFERS/DRIVERS WITH 3-STATE OUTPUTS

SCAS354 – FEBRUARY 1994

- State-of-the-Art Advanced BiCMOS Technology (ABT) Design for 3.3-V Operation and Low-Static Power Dissipation
- Supports Mixed-Mode Signal Operation (5-V Input and Output Voltages With 3.3-V  $V_{CC}$ )
- Supports Unregulated Battery Operation Down to 2.7 V
- Typical  $V_{OLP}$  (Output Ground Bounce)  $< 0.8$  V at  $V_{CC} = 3.3$  V,  $T_A = 25^\circ\text{C}$
- Latch-Up Performance Exceeds 500 mA Per JEDEC Standard JESD-17
- Bus-Hold Data Inputs Eliminate the Need for External Pullup Resistors
- Supports Live Insertion
- Package Options Include Plastic Small-Outline (DW), Shrink Small-Outline (DB), and Thin Shrink Small-Outline (PW) Packages, Ceramic Chip Carriers (FK), and Ceramic DIPs (J)

## description

These octal buffers and line drivers are designed specifically for low-voltage (3.3-V)  $V_{CC}$  operation, but with the capability to provide a TTL interface to a 5-V system environment.

The 'LVT244A is organized as two 4-bit line drivers with separate output-enable ( $\overline{OE}$ ) inputs. When  $\overline{OE}$  is low, the device passes data from the A inputs to the Y outputs. When  $\overline{OE}$  is high, the outputs are in the high-impedance state.

Active bus-hold circuitry is provided to hold unused or floating data inputs at a valid logic level.

To ensure the high-impedance state during power up or power down,  $\overline{OE}$  should be tied to  $V_{CC}$  through a pullup resistor; the minimum value of the resistor is determined by the current-sinking capability of the driver.

The SN74LVT244A is available in TI's shrink small-outline package (DB), which provides the same I/O pin count and functionality of standard small-outline packages in less than half the printed-circuit-board area.

The SN54LVT244A is characterized for operation over the full military temperature range of  $-55^\circ\text{C}$  to  $125^\circ\text{C}$ . The SN74LVT244A is characterized for operation from  $-40^\circ\text{C}$  to  $85^\circ\text{C}$ .

SN54LVT244A . . . J PACKAGE  
SN74LVT244A . . . DB, DW, OR PW PACKAGE  
(TOP VIEW)

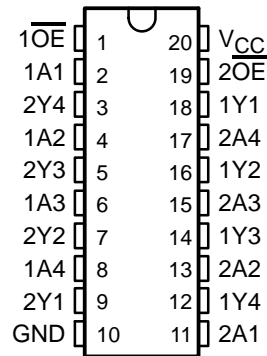

SN54LVT244A . . . FK PACKAGE  
(TOP VIEW)

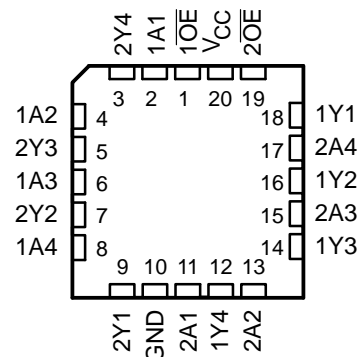

FUNCTION TABLE  
(each buffer)

INPUTS		OUTPUT
$\overline{OE}$	A	Y
L	H	H
L	L	L
H	X	Z

# SN54LVT244A, SN74LVT244A 3.3-V ABT OCTAL BUFFERS/DRIVERS WITH 3-STATE OUTPUTS

SCAS354 – FEBRUARY 1994

## logic symbol†

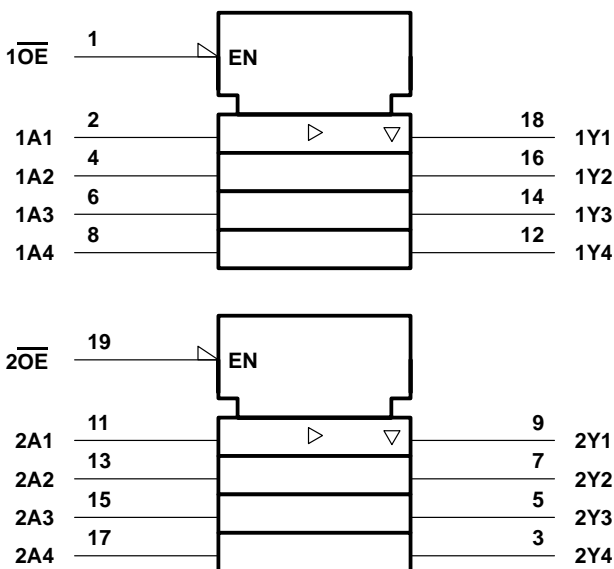

† This symbol is in accordance with ANSI/IEEE Std 91-1984 and IEC Publication 617-12.

## logic diagram (positive logic)

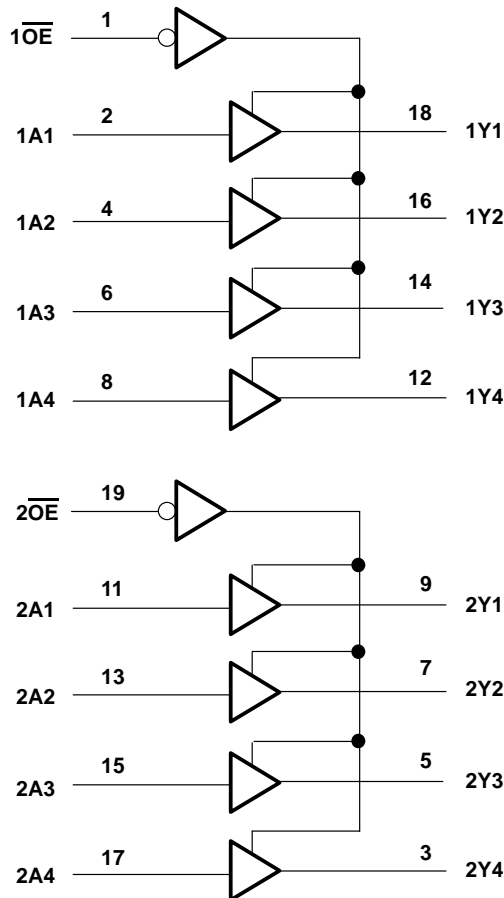

## absolute maximum ratings over operating free-air temperature range (unless otherwise noted)‡

Supply voltage range, $V_{CC}$ .....	-0.5 V to 4.6 V
Input voltage range, $V_I$ (see Note 1) .....	-0.5 V to 7 V
Voltage range applied to any output in the high state or power-off state, $V_O$ (see Note 1) .....	-0.5 V to 7 V
Current into any output in the low state, $I_O$ : SN54LVT244A .....	96 mA
SN74LVT244A .....	128 mA
Current into any output in the high state, $I_O$ (see Note 2): SN54LVT244A .....	48 mA
SN74LVT244A .....	64 mA
Input clamp current, $I_{IK}$ ( $V_I < 0$ ) .....	-50 mA
Output clamp current, $I_{OK}$ ( $V_O < 0$ ) .....	-50 mA
Maximum power dissipation at $T_A = 55^\circ\text{C}$ (in still air) (see Note 3): DB package .....	0.6 W
DW package .....	1.6 W
PW package .....	0.7 W
Storage temperature range .....	-65°C to 150°C

‡ Stresses beyond those listed under "absolute maximum ratings" may cause permanent damage to the device. These are stress ratings only, and functional operation of the device at these or any other conditions beyond those indicated under "recommended operating conditions" is not implied. Exposure to absolute-maximum-rated conditions for extended periods may affect device reliability.

- NOTES:
1. The input and output negative-voltage ratings may be exceeded if the input and output clamp-current ratings are observed.
  2. This current will only flow when the output is in the high state and  $V_O > V_{CC}$ .
  3. The maximum package power dissipation is calculated using a junction temperature of 150°C and a board trace length of 750 mils. For more information, refer to the *Package Thermal Considerations* application note.

**SN54LVT244A, SN74LVT244A**  
**3.3-V ABT OCTAL BUFFERS/DRIVERS**  
**WITH 3-STATE OUTPUTS**  
 SCAS354 – FEBRUARY 1994

**recommended operating conditions (see Note 4)**

		SN54LVT244A		SN74LVT244A		UNIT
		MIN	MAX	MIN	MAX	
$V_{CC}$	Supply voltage	2.7	3.6	2.7	3.6	V
$V_{IH}$	High-level input voltage	2		2		V
$V_{IL}$	Low-level input voltage		0.8		0.8	V
$V_I$	Input voltage		5.5		5.5	V
$I_{OH}$	High-level output current		-24		-32	mA
$I_{OL}$	Low-level output current		48		64	mA
$\Delta t/\Delta v$	Input transition rise or fall rate	Outputs enabled			10	ns/V
$T_A$	Operating free-air temperature	-55	125	-40	85	°C

NOTE 4: Unused or floating control inputs must be held high or low.

# SN54LVT244A, SN74LVT244A

## 3.3-V ABT OCTAL BUFFERS/DRIVERS

### WITH 3-STATE OUTPUTS

SCAS354 – FEBRUARY 1994

electrical characteristics over recommended operating free-air temperature range (unless otherwise noted)

PARAMETER	TEST CONDITIONS		SN54LVT244A		SN74LVT244A		UNIT		
			MIN	TYP†	MAX	MIN		TYP†	MAX
$V_{IK}$	$V_{CC} = 2.7\text{ V}$ , $I_I = -18\text{ mA}$				-1.2		V		
$V_{OH}$	$V_{CC} = \text{MIN to MAX}^\ddagger$ , $I_{OH} = -100\ \mu\text{A}$		$V_{CC} - 0.2$		$V_{CC} - 0.2$		V		
	$V_{CC} = 2.7\text{ V}$ , $I_{OH} = -8\text{ mA}$		2.4		2.4				
	$V_{CC} = 3\text{ V}$ , $I_{OH} = -24\text{ mA}$		2						
	$V_{CC} = 3\text{ V}$ , $I_{OH} = -32\text{ mA}$				2				
$V_{OL}$	$V_{CC} = 2.7\text{ V}$ , $I_{OL} = 100\ \mu\text{A}$				0.2		V		
	$V_{CC} = 2.7\text{ V}$ , $I_{OL} = 24\text{ mA}$				0.5				
	$V_{CC} = 3\text{ V}$ , $I_{OL} = 16\text{ mA}$				0.4				
	$V_{CC} = 3\text{ V}$ , $I_{OL} = 32\text{ mA}$				0.5				
	$V_{CC} = 3\text{ V}$ , $I_{OL} = 48\text{ mA}$				0.55				
	$V_{CC} = 3\text{ V}$ , $I_{OL} = 64\text{ mA}$				0.55				
$I_I$	$V_{CC} = 0\text{ or MAX}^\ddagger$ , $V_I = 5.5\text{ V}$				10		$\mu\text{A}$		
	$V_{CC} = 3.6\text{ V}$ , $V_I = V_{CC}\text{ or GND}$		Control pins		$\pm 1$				
	$V_{CC} = 3.6\text{ V}$ , $V_I = V_{CC}$		Data pins		1				
	$V_{CC} = 3.6\text{ V}$ , $V_I = 0$				-5				
$I_{off}$	$V_{CC} = 0$ , $V_I\text{ or }V_O = 0\text{ to }4.5\text{ V}$				$\pm 100$		$\mu\text{A}$		
$I_{I(\text{hold})}$	$V_{CC} = 3\text{ V}$	$V_I = 0.8\text{ V}$	A inputs		75		$\mu\text{A}$		
		$V_I = 2\text{ V}$			-75				
$I_{OZH}$	$V_{CC} = 3.6\text{ V}$ , $V_O = 3\text{ V}$				5		$\mu\text{A}$		
$I_{OZL}$	$V_{CC} = 3.6\text{ V}$ , $V_O = 0.5\text{ V}$				-5		$\mu\text{A}$		
$I_{CC}$	$V_{CC} = 3.6\text{ V}$ , $I_O = 0$ , $V_I = V_{CC}\text{ or GND}$		Outputs high		0.12	0.5	0.12	0.19	mA
			Outputs low		8.6	14	8.6	12	
			Outputs disabled		0.12	0.5	0.12	0.19	
$\Delta I_{CC}^\S$	$V_{CC} = 3\text{ V to }3.6\text{ V}$ , One input at $V_{CC} - 0.6\text{ V}$ , Other inputs at $V_{CC}\text{ or GND}$				0.3		0.2	mA	
$C_i$	$V_I = 3\text{ V or }0$				4		pF		
$C_o$	$V_O = 3\text{ V or }0$				8		pF		

† All typical values are at  $V_{CC} = 3.3\text{ V}$ ,  $T_A = 25^\circ\text{C}$ .

‡ For conditions shown as MIN or MAX, use the appropriate value specified under recommended operating conditions.

§ This is the increase in supply current for each input that is at the specified TTL voltage level rather than  $V_{CC}$  or GND.

**SN54LVT244A, SN74LVT244A**  
**3.3-V ABT OCTAL BUFFERS/DRIVERS**  
**WITH 3-STATE OUTPUTS**  
SCAS354 – FEBRUARY 1994

switching characteristics over recommended operating free-air temperature range,  $C_L = 50 \text{ pF}$   
(unless otherwise noted) (see Note 5)

PARAMETER	FROM (INPUT)	TO (OUTPUT)	SN54LVT244A				SN74LVT244A				UNIT	
			$V_{CC} = 3.3 \text{ V} \pm 0.3 \text{ V}$		$V_{CC} = 2.7 \text{ V}$		$V_{CC} = 3.3 \text{ V} \pm 0.3 \text{ V}$			$V_{CC} = 2.7 \text{ V}$		
			MIN	MAX	MIN	MAX	MIN	TYP	MAX	MIN		MAX
$t_{PLH}$	A	Y	0.5	4.7		5.2	1	2.5	4.1		5	ns
$t_{PHL}$			0.5	4.4		5.4	1	2.5	4.1		5.2	
$t_{PZH}$	$\overline{\text{OE}}$	Y	0.8	5.4		6.5	1	2.7	5.2		6.3	ns
$t_{PZL}$			0.8	5.4		7.6	1.1	3.1	5.2		6.7	
$t_{PHZ}$	$\overline{\text{OE}}$	Y	1.5	6.2		6.9	1.9	3.9	5.6		6.3	ns
$t_{PLZ}$			1.2	5.5		6	1.8	3.2	5.1		5.6	

NOTE 5: Load circuit and voltage waveforms are shown in Section 1.



## **IMPORTANT NOTICE**

Texas Instruments (TI) reserves the right to make changes to its products or to discontinue any semiconductor product or service without notice, and advises its customers to obtain the latest version of relevant information to verify, before placing orders, that the information being relied on is current.

TI warrants performance of its semiconductor products and related software to the specifications applicable at the time of sale in accordance with TI's standard warranty. Testing and other quality control techniques are utilized to the extent TI deems necessary to support this warranty. Specific testing of all parameters of each device is not necessarily performed, except those mandated by government requirements.

Certain applications using semiconductor products may involve potential risks of death, personal injury, or severe property or environmental damage ("Critical Applications").

**TI SEMICONDUCTOR PRODUCTS ARE NOT DESIGNED, INTENDED, AUTHORIZED, OR WARRANTED TO BE SUITABLE FOR USE IN LIFE-SUPPORT APPLICATIONS, DEVICES OR SYSTEMS OR OTHER CRITICAL APPLICATIONS.**

Inclusion of TI products in such applications is understood to be fully at the risk of the customer. Use of TI products in such applications requires the written approval of an appropriate TI officer. Questions concerning potential risk applications should be directed to TI through a local SC sales office.

In order to minimize risks associated with the customer's applications, adequate design and operating safeguards should be provided by the customer to minimize inherent or procedural hazards.

TI assumes no liability for applications assistance, customer product design, software performance, or infringement of patents or services described herein. Nor does TI warrant or represent that any license, either express or implied, is granted under any patent right, copyright, mask work right, or other intellectual property right of TI covering or relating to any combination, machine, or process in which such semiconductor products or services might be or are used.